



# Spotter

User Guide







# Spotter

User Guide

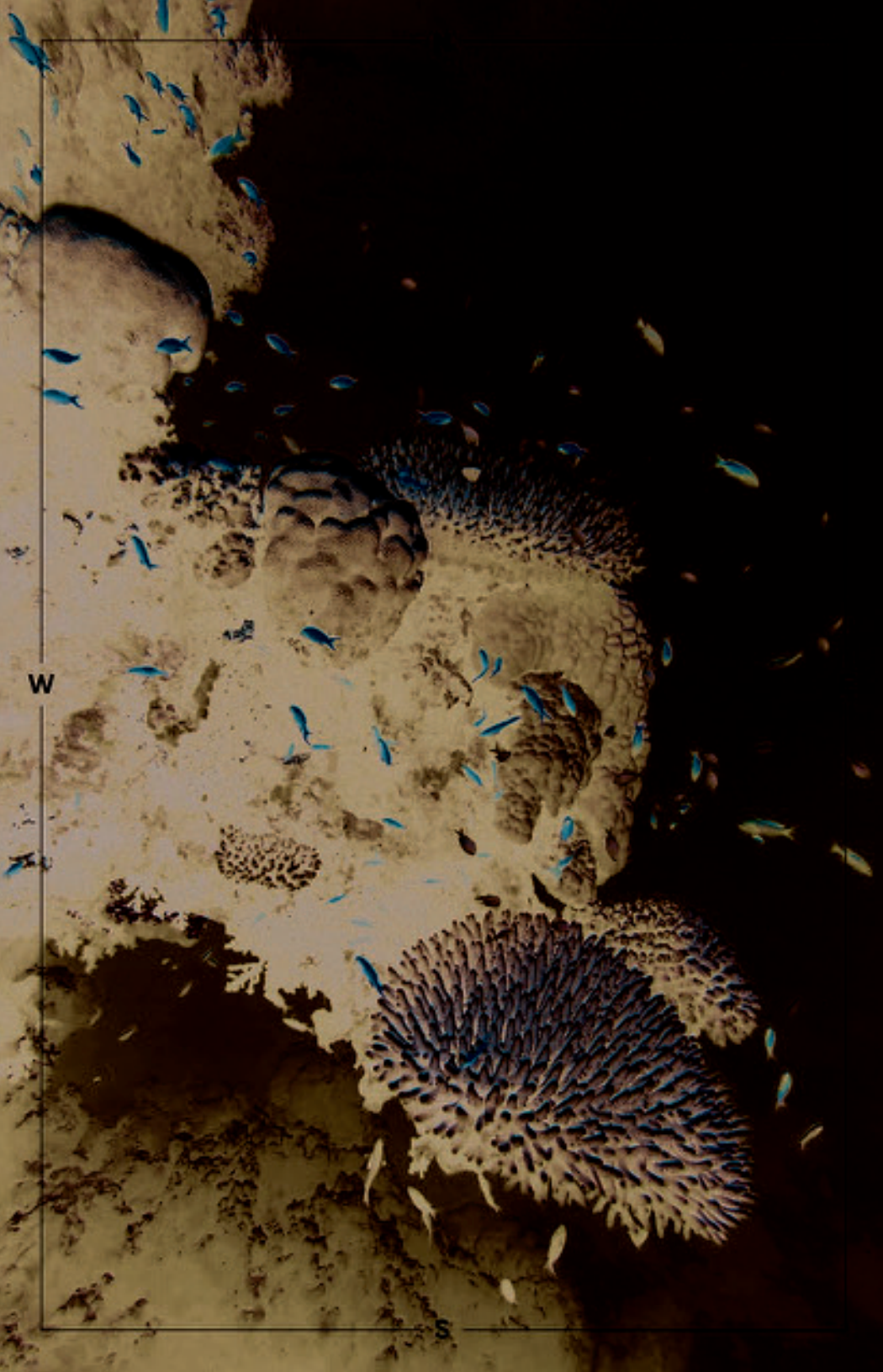

# Table of Contents

**06**    **What's Included**

---

**07**    **Sofar Spotter**

---

**08**    **Core Features**

---

**09**    **User Interface**

---

**10**    **Getting Started**

---

**20**    **Data Access & Spotter Measurements**

---

**22**    **Product Specifications**

---

**25**    **Safety & Compliance**



Scan the QR code to access  
online Support page

# Sofar Spotter

Spotter is an integrated solution for collecting ocean data. The Spotter platform consists of a globally-connected buoy (“Spotter”), the online Spotter Dashboard, and the Spotter Data API.

The Dashboard allows you to configure your Spotter remotely and provides access to real-time Spotter ocean and tracking data, system status, alerts, and data visualization.

## CORE SYSTEM FEATURES

### 2-Way Communication

Remotely change settings on Spotter through the online Dashboard.

### Alerts + Notifications

Set a system or measurement alert and receive notifications when thresholds are reached.

### Spotter API

Access Spotter data via our API for seamless application integration.

### Track Mode

Fast positional updates for tracking Spotter through the Dashboard.

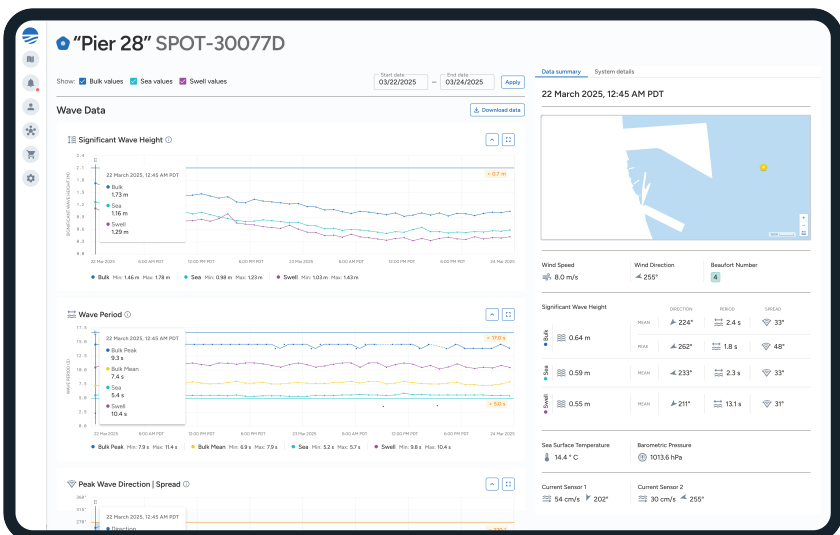

# What's Included

## Spotter device

---

### Spotter toolkit, including:

---

- A** Bow shackle for attaching a mooring line
- B** 5mm hex key to open and close the lid of Spotter
- C** Lanyard and magnet to switch between **IDLE** and **RUN** mode(s)
- D** SD card for data storage during deployment (shipped with unit)
- E** USB-C power charger to charge the battery prior to deployment
- F** Marine-safe desiccant to reduce moisture inside Spotter
- G** Mousing wire to secure shackles

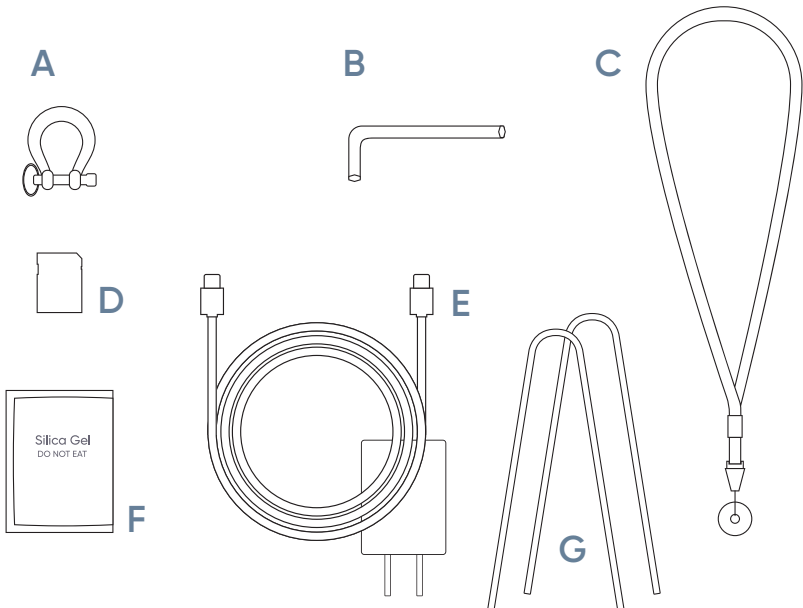

# Core Features

Spotter is a compact and lightweight instrument consisting of a waterproof hull, solar panel array, and electronics package.

Spotter is completely solar-powered, so you don't have to replace or recharge the battery during deployment. The solar-battery power system is designed to support Spotter at higher latitudes in limited light conditions.

Spotter stores the data it collects on its onboard SD card and transmits condensed forms of that data over cellular and satellite connections.

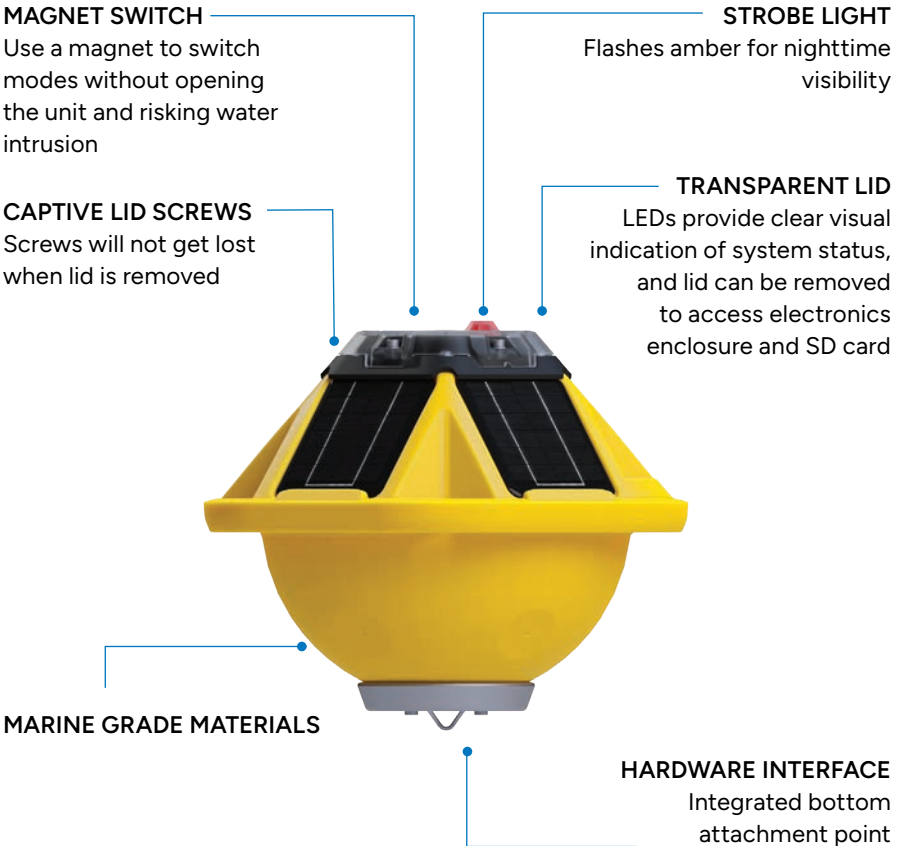

*For mooring applications see p. 16*

# User Interface

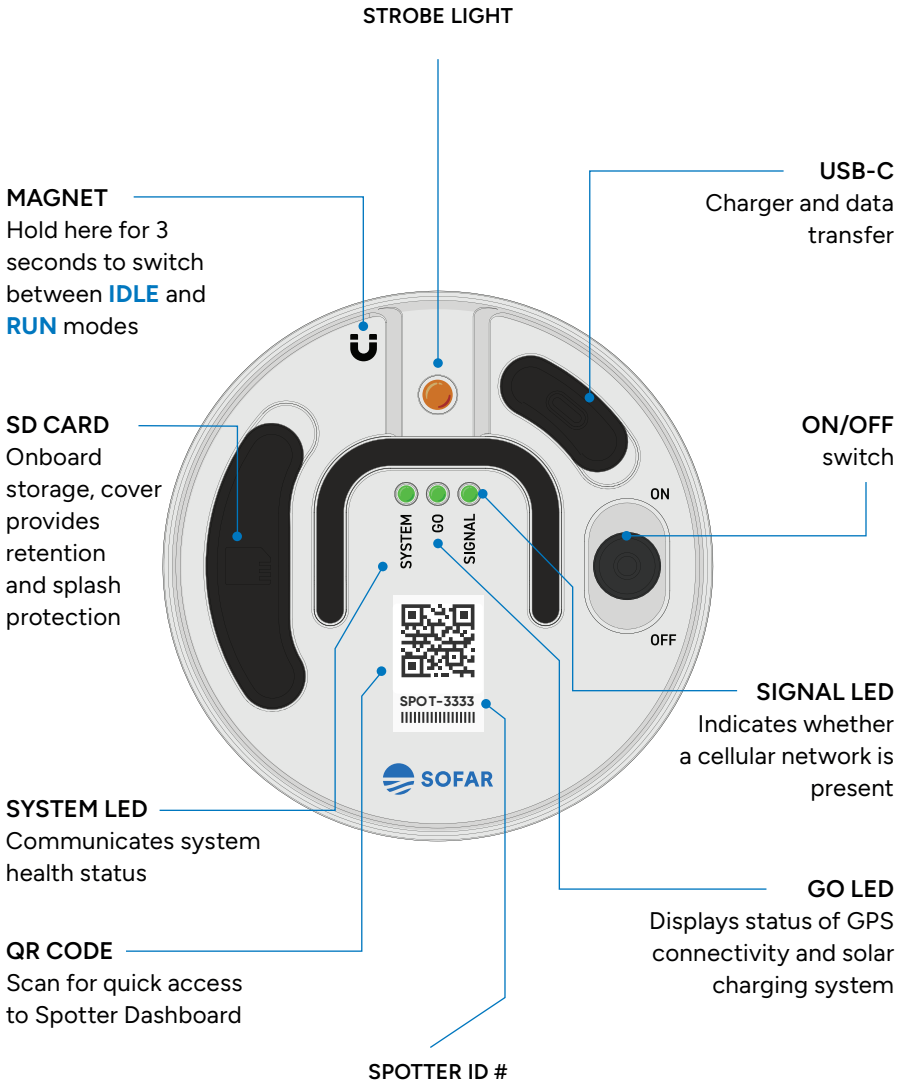

# Getting Started

10                    **STEP 01**  
**Set up account and register Spotter**

---

12                    **STEP 02**  
**Set up Spotter device**

---

16                    **STEP 03**  
**Deploy Spotter in the water**

---

17                    **STEP 04**  
**Check your Spotter Dashboard**

---

18                    **STEP 05**  
**Retrieve and store Spotter**

# Set up account and register Spotter



## Set up user account

Visit [spotter.sofaroccean.com](https://spotter.sofaroccean.com) to set up your user account. Click “Create an account,” enter personal details, and click “Register.” This will take you to the overview page.

## Register your Spotter

To register your Spotter, click ☰ and then “Register Spotter.”

Enter your Spotter ID number and your activation code, which you should have received by email from the Sofar team. If you have not received this, or do not have this available anymore, please contact Sofar at: [support@sofarocean.com](mailto:support@sofarocean.com)

Your Spotter ID number is also listed on the device, and looks like SPOT-#####. After entering this information, click “Register.”

You will now see your Spotter listed on the overview page. The map will update as soon as the first data message is received, which typically takes 1-1.5 hrs from device power on. Please note that message and data transmission require a clear view of the sky with minimal obstruction in order to establish a GPS signal and communicate effectively.



Spotter requires a clear view of the sky with minimal obstruction.

## STEP 02

# Set up Spotter device

## Ready to go

Spotter device is completely self-powered and can be operated right out of the box.

## Check the SD card

When inserting or checking the SD card, please make sure the card is properly seated. The SYSTEM LED will turn red if the card is not seated correctly.

## Turn Spotter on

Switch the on/off switch to the “on” position to turn Spotter on. During boot-up, the SYSTEM and GO LEDs will be orange, and after startup they will switch to green. Spotter has two possible operating modes: **IDLE** mode and **RUN** mode. You can switch between modes using the provided magnet by holding it at the designated area for 3 seconds. Spotter will always boot into the last mode it was in before it was switched off.

## Check cellular network

Spotter comes equipped with cellular connectivity. For more information about cellular data transmission, data plans, firmware updates, and how you can use Spotter’s SIGNAL LED to determine whether the cellular signal is strong enough at your desired deployment location, please visit [www.sofarocan.com/support-docs/cellular](http://www.sofarocan.com/support-docs/cellular)

### MAGNET

Hold here for 3 seconds to switch between **IDLE** and **RUN** modes

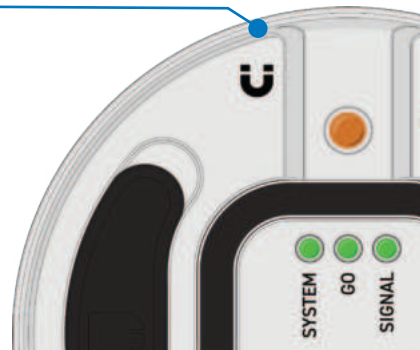

## IDLE

In **IDLE** mode, the SYSTEM and GO LEDs alternate flashing green. The strobe light will be OFF.

**IDLE** mode is to save power and suspend data acquisition and transmission. Using the magnet, you can switch to **RUN** mode without having to open the lid.

Use **IDLE** mode for short-term inactivity, in preparation for deployment (e.g. transport to deployment site).

## RUN

In **RUN** mode, the SYSTEM and GO LEDs are solid green and the amber strobe light flashes periodically.

**RUN** mode is for full system functionality, including: data acquisition, processing, data transmission, and onboard logging to SD card.

Use **RUN** mode during deployment.

*Note: Spotter DOES NOT collect data when in **IDLE** mode.*

## Important

- Spotter needs to be switched into **RUN** mode for deployment.
- If Spotter is in **IDLE** mode, you can switch to **RUN** mode by holding a magnet onto the recessed area directly on top of the electronics box until the lights turn off. Or, if the transparent lid is screwed on, hold the magnet onto the recessed round area in the lid for 3 seconds.
- The flashing pattern of the the SYSTEM and GO LEDs and the strobe light will reveal which mode Spotter is in. (See next pages.)
- In **IDLE** mode, the SYSTEM and GO LEDs will shut off after 3 minutes to save power.
- When switched to **RUN** mode, the SYSTEM and GO LEDs communicate system status and signal when Spotter is ready to deploy.

## Explanation of user LEDs

### SYSTEM LED

Communicates system health status

### GO LED

Displays status of GPS connectivity and solar charging system

### SIGNAL LED

Indicates whether messages are transmitting over cellular

# Explanation of user LEDs (*continued*)

## IDLE mode

---

SYSTEM GO SIGNAL AT STARTUP



**Both solid orange.** System is booting up and running self-check.

AFTER STARTUP



**Blinking green.** The system is in **IDLE** mode. Flashes in alternating pattern between SYSTEM and GO LEDs for 3 minutes and then turns off.

## CHARGING mode

---

**Note:** While OFF and connected to a DC charger, Spotter's lights will indicate its charge status. Please note that charging Spotter can take as long as 8 hours.

SYSTEM GO SIGNAL



**Both solid green.** System is fully charged.



**Blinking green in sync.** System is charging.



**Both solid red.** Battery error, battery is not connected.



**Both blinking red.** Charging error, device is connected to DC power but not charging properly.

## RUN mode

---

SYSTEM GO SIGNAL AT STARTUP



**Both solid orange.** System is booting up and running self-check.

AFTER STARTUP







**Both solid green.** All systems are checked and OK. Ready to deploy. Both LEDs will time out after 60 minutes to save power.

## RUN mode (continued)

---

### SYSTEM GO SIGNAL AFTER STARTUP (CONTINUED)



-  **Blinking green GO LED.** System is not solar charging but is trying to acquire GPS signal. If this is a night deployment or the panels are covered, ignore and deploy. If this is a day deployment, something is wrong with the charging system. Do not deploy.
-  **Solid red SYSTEM LED.** Check if SD card is present. If not, turn off system, insert a freshly formatted SD card, and switch back on. If the red light persists, there may be a serious system error. Do not deploy until this is resolved and please contact the Sofar team.
-  **Solid red GO LED.** Limited GPS connectivity. Ensure system is outside with a clear view of the sky. Wait a few minutes for system to connect with the GPS satellite. If the system has a clear view of the sky and the GO LED remains red for longer than 30 minutes, something may be wrong. Please contact the Sofar team.
-  **Both solid red.** Do not deploy. Follow instructions for red SYSTEM or GO LED detailed above.

## Connectivity

---

**Note:** the SIGNAL LED on satellite-only systems is always unlit.

### SYSTEM GO SIGNAL

-  **All Solid Green.** Cellular data is available; ready to deploy.
-  **Solid red SIGNAL LED.** Cellular data is not available; if deployed, unit will still be able to use Iridium.
-  **Blinking orange SIGNAL LED.** Cellular data is syncing, please be patient

## STEP 03

# Deploy Spotter in the water

## Activate Spotter in **RUN** mode

Switch Spotter ON and ensure Spotter is in **RUN** mode. Ensure both SYSTEM and GO LEDs are green after ~10 minutes with a clear view of the sky. In warm environments, don't leave systems out of the water in direct sun for more than 3 hours when dry testing. This will cause the battery to overheat and the system will disable charging to protect it.

Please note that the SYSTEM and GO LEDs time out after 60 minutes to save power. After 60 minutes you can see that the system is in **RUN** mode from the flashing of the strobe light.

## Carefully secure lid

Secure the lid using a 5 mm hex key and hand-tighten (~10 in-lbs of torque) the 5 captive screws (with washers) using a star pattern. The captive screws will bottom out to prevent over-tightening.

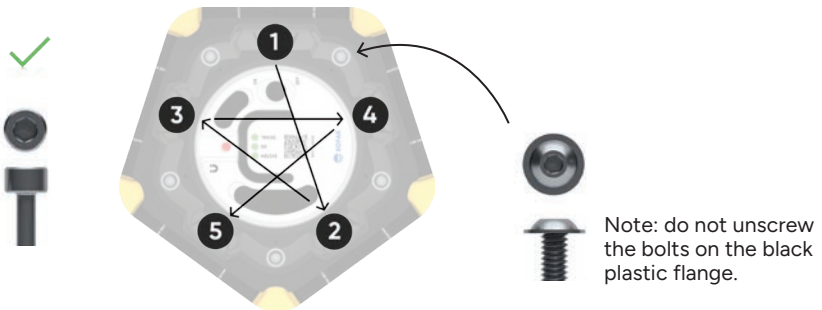

**Note on Mooring Design:** Spotter can be deployed either as a free-floating drifter or in a moored configuration. For free-floating deployments, Spotter comes with everything required to deploy. For moored applications, you will need to design a mooring to anchor Spotter to the seafloor.

Visit [www.sofaroccean.com/support](http://www.sofaroccean.com/support) for more information on mooring guidelines.

## Check your Spotter Dashboard

### Log in to your account

Visit [spotter.sofaroccean.com](https://spotter.sofaroccean.com) to log in to your user account. Once you are logged in you are on the overview page. If your Spotter has been deployed, it will display as a pulsing dot on the map. In that case, Spotter is set up properly and you can access your data.

Currently the Dashboard allows you to:

- View real-time surface wave data from your Spotter.
- Search and download historical data for a custom date range.
- Track your Spotter on the map so you can plot and estimate surface currents or anticipate a retrieval strategy.
- Set a geofence so that you are notified if Spotter detaches from its mooring or otherwise moves outside the set boundaries.
- Add measurement alert so that you are notified if Spotter observes something of interest.
- Remotely switch Spotter between Waves and Track mode. See the “Spotter Measurements” section on page 20 to determine which mode you need for your application.
- Access our API to integrate ocean data into your own applications.
- Review health status of your Spotter (battery, system status) and get notified when something is off.
- Check and renew your data subscription.
- Change your personal profile.

Besides the features described above, we are constantly developing new functionality for Spotter, so keep an eye on the Spotter Dashboard for the latest news and updates.

**Note:** Instructions for the Dashboard were included in the email that you received with your activation code.

## Retrieve and store Spotter

### Retrieve Spotter

After retrieval, disconnect the mooring and rinse off Spotter and mooring with fresh water before storage. If any fouling has built up on Spotter, this can generally be removed with a soft brush and soapy water.

### Turn the device off for storage

After rinsing, dry the area around the lid and unscrew the lid using the 5mm hex key. Remove the lid carefully to prevent water from dropping onto the electronics box. After the lid is removed, turn the device off using the on/off switch. At this point you can also remove the SD card and download the data stored on the card to your personal computer.

If you plan to store Spotter for a longer period of time, please see the notes on “Lithium-ion battery use and storage” below.

If you plan to deploy after a prolonged storage period, we recommend that you use the wall charger provided to fully charge Spotter before deployment. This ensures that the system can start up and operate without delay.

Before redeployment, we recommend that you replace the desiccant inside the Ebox. Spare desiccant can be found inside the included Spotter accessory kit. In most models of Spotter, the desiccant will change color from its natural orange to a dark green as it becomes more saturated.

### Lithium-ion battery use and storage

Spotter units are equipped with a lithium-ion battery pack, which is located inside the electronics box. It is important to handle Spotter with care to prevent any possible damage to the electronics and battery pack. For prolonged storage (longer than a week), Spotter should ideally be stored in a cool (< 25°C) and dry area with the battery at a medium charge. Never store Spotter in < -20°C.

Lithium-ion battery packs stored at or near full charge for extended periods of time can experience a reduction in battery capacity. Therefore, if planning to store for longer than 1 week, we advise that the battery not be fully charged. One way to ensure proper state of battery charge is to run the system for two days without solar power (in a box or dark room) before turning it off and putting it in storage.

## **Avoid submersion of Spotter**

Spotter is not rated for continuous submersion. Continuous submersion can lead to damage or failure of critical components, such as the barometer or sea surface temperature sensor. Possible causes of continuous submersion include:

- Excessive biofouling accumulation on Spotter or mooring lines.
- A Spotter moored directly in the surf zone or in a way where it is pulled through the face of a breaking wave.
- Moorings with too much drag or that are missing the required surface float(s) recommended in the mooring guidelines.
- Moorings that are incompatible with site-specific ocean conditions, such as waves and currents.

Please see the Support section of our website for the latest guidelines on mooring and maintaining your Spotter:

[www.sofaroccean.com/support](http://www.sofaroccean.com/support)

# Data Access & Spotter Measurements

## Data Access

Spotter collects displacement (3D movement) data continuously at 2.5Hz. This data is stored as a time series on the onboard SD card and sent to Sofar's online Dashboard and APIs. Depending on which mode Spotter is in, different data is available in different places. To learn more about data access visit [www.sofaroccean.com/support](http://www.sofaroccean.com/support)

## Spotter Measurements

Spotter has several modes that can be set remotely through the online Dashboard. Spotter modes can be changed and further customized to fit various applications. To learn more about the different modes and how to enable them, visit:

[www.sofaroccean.com/posts/spotter-data-modes](http://www.sofaroccean.com/posts/spotter-data-modes)

### Waves:Standard mode

Waves:Standard is the default mode and is recommended for most marine monitoring applications. Displacement data is collected continuously at 2.5Hz. Every 30 minutes, Spotter computes wave and wind statistics. To save transmission bandwidth, two time-stamped 30 minute bulk statistics are transmitted every hour.

The standard bulk statistics includes these parameters:

- Position (latitude and longitude)
- Significant Wave Height
- Peak/Mean Period
- Peak/Mean Direction
- Peak/Mean Directional Spread

*All bulk statistics are computed over frequency range 0.03 – 0.8Hz.  
For definitions of various bulk wave statistics see e.g. Holthuijsen (2007).*

## Waves:Partition

Waves:Partition mode is a balance between Standard and Spectrum modes. In this mode, Spotter also provides the same bulk parameters for two “sea” (short period) and “swell” (long period) wave partitions. Waves:Partition uses a 60 minute sample window.

## Waves:Spectrum

Waves:Spectrum is recommended for deeper analysis, modeling, and science applications. In this mode, Spotter transmits the variance density spectrum and directional moments as a function of frequency. Waves:Spectrum uses a 60 minute sample period to improve the statistical estimate of spectrum and directional moments. Waves:Spectrum has an adjustable update rate of between 1 and 6 hours.

**Note:** Spectrum data is only available via the API, bulk statistics will still be displayed on the Dashboard.

**Note:** Update rates faster than 6 hours will incur higher data usage costs than Waves:Standard mode due to the increased amount of data transmitted.

## High Data Rate (HDR) — Cellular Only

Spotters with cellular connectivity can take advantage of low cost and high bandwidth LTE networks to transmit richer data. Spotter data sent over HDR can be used to generate the data from all the modes described above - and more - at a fraction of the cost. Sample and update rates can be configured to as short as 15 minutes.

## Track Mode

Track mode is intended for retrieval of free-drifting Spotters or for other tracking needs. In Track mode, positional updates are transmitted every 15 minutes. Spotter does not transmit wave data when in Track mode, but data is stored locally to the SD card.

# Product Specifications

## Data and Connectivity

---

Connectivity	Iridium SBD (satellite) and Cellular
--------------	--------------------------------------

---

Data storage and access <sup>01</sup>	<ol style="list-style-type: none"><li>1. Full-size 16GB SD card (onboard) - saves displacement time series, spectra and statistics, surface currents, and positions for 1 year</li><li>2. Online Dashboard - unlimited real-time wave statistics and tracking data</li><li>3. Spotter Data API - access both the latest and historical data</li></ol>
---------------------------------------	---

---

Applications	<p><b>Free-drifting:</b> Spotter measures waves, position and surface currents, designed to operate in any current speed</p> <p><b>Moored:</b> Spotter measures waves and position, plus whichever sensors are attached</p>
--------------	---

---

Spotter is equipped to transmit data globally via a cellular modem or by Iridium satellite connection. For more information about connectivity and data plans, please visit [www.sofaroccean.com/support](http://www.sofaroccean.com/support)

## Onboard Data Analysis

---

Spectral output	Function of frequency: variance density spectrum, directional moments, mean direction, directional spreading.
-----------------	---

---

Frequency range	0.033 - 1 Hz (30s - 1s)
-----------------	-------------------------

---

Frequency resolution	0.0098 Hz
----------------------	-----------

---

Bulk statistics	Significant wave height, mean period, peak period, mean direction, mean directional spread, peak direction, peak directional spread
-----------------	---

---

<sup>01</sup>For more information, please visit:  
[www.sofaroccean.com/posts/spotter-data-access](http://www.sofaroccean.com/posts/spotter-data-access)

## Power, System Upgrade, and Monitoring

<b>Primary power source</b>	Solar-powered, 5× 2 Watt, 6 Volt solar panels
<b>Battery</b>	Rechargeable Lithium-ion 13,400 mAh capacity, 3.7 Volts
<b>Firmware upgrade</b>	Standard USB-C connector (cable included), Over-the-Air upgrades for cellular Spotters
<b>System monitoring</b>	Internal temperature, humidity, and solar charging monitored for system health

## Motion Sensing

<b>Motion data format</b>	Easting, northing, elevation, latitude, longitude
<b>Wave frequency range</b>	0.03 - 1 Hz (30s - 1s)
<b>Wave direction range</b>	0 - 360 degrees (full circle)
<b>Sampling rate</b>	2.5 Hz (Nyquist at 1.25 Hz)
<b>Wave displacement accuracy</b>	Approximately $\pm 2$ cm , practical accuracy depends on field of view, conditions, and GPS system status

## Additional Onboard Sensors

<b>Sea surface temperature</b> <small>(Not included with Spotters with Smart Mooring)</small>	Range	-5°C - 50°C
	Accuracy	0.1 °C absolute
	Resolution	$\pm 0.02$ °C
<b>Barometer (Station Pressure)</b>	Range	700 - 1100mbar
	Accuracy	$\pm 0.5$ mbar at 25°C

# Product Specifications

## Dimensions and Weight

Weight	7.45 kg (16 lbs, 7 oz)
Height	31 cm (12.2 in)
Width	42 cm (16.5 in)

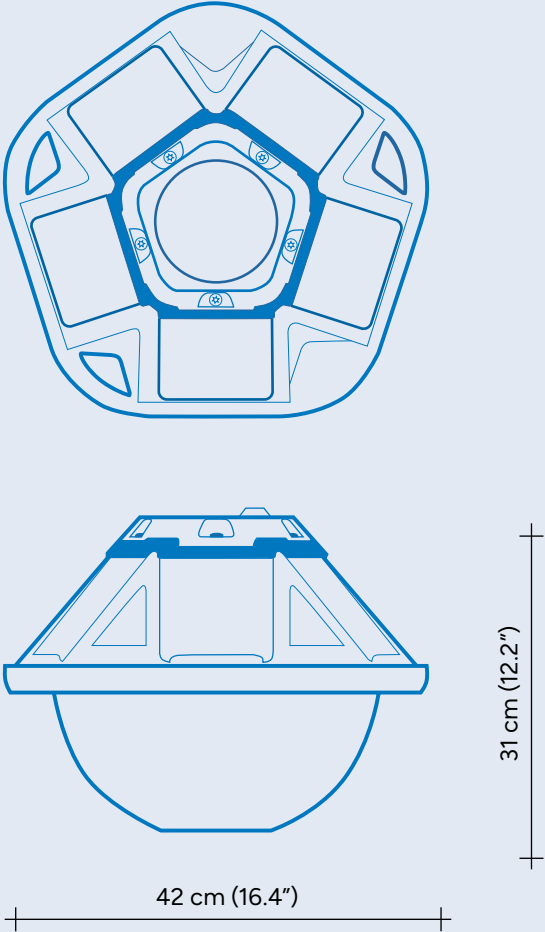

# Legal

## Trademarks and Patenting

Sofar Spotter and other Sofar products are covered by U.S. and international patents. For a full list of Sofar's patents, please refer to: [www.sofaroccean.com/legal/patents](http://www.sofaroccean.com/legal/patents)

The Sofar logo and the terms "Sofar Ocean" and "Spotter" are trademarks belonging to Sofar Ocean Technologies, Inc ("Sofar Ocean"). All other related designs, text, graphics, pictures, videos, or any other proprietary intellectual property included with this purchase are the property of Sofar Ocean or its vendors or licensors.

## Terms and Policies

Your purchase and use of Spotter, including any associated software, is subject to the following Sofar policies:

Sofar Terms of Sale

Sofar Terms of Use

Privacy Policy

Warranty Policy

Return Policy

[www.sofaroccean.com/legal](http://www.sofaroccean.com/legal)

Should you have any questions about these policies or your rights and responsibilities relating thereto, please contact Sofar at:

[support@sofarocean.com](mailto:support@sofarocean.com)



Scan the QR code to visit  
our online Support Page

# Safety & Compliance

## FCC Compliance Statement

This equipment has been tested and found to comply with the limits for a Class A digital device, pursuant to part 15 of the FCC (Federal Communications Commission) Rules. These limits are designed to provide reasonable protection against harmful interference when the equipment is operated in a commercial environment. This equipment generates, uses, and can radiate radio frequency energy and, if not installed and used in accordance with the instruction manual, may cause harmful interference to radio communications. Operation of this equipment in a residential area is likely to cause harmful interference in which case the user will be required to correct the interference at his own expense. Changes or modifications not expressly approved by Sofar could void your warranty and your authority to operate this equipment.

This device complies with Part 15 of the FCC Rules. Operation is subject to the following two conditions: (1) this device may not cause harmful interference, and (2) this device must accept any interference received, including interference that may cause undesired operations.

This device contains a certified transmitter module which is located in the electronics package, FCC number Q639603N.

 <b>CAUTION</b>	
	<p>If the device is damaged due to water ingress or otherwise, do not use or charge your Spotter, and disconnect the solar panels.</p> <hr/>
	<p>Lithium batteries and products that contain them must be disposed of properly. Contact your local waste management company or municipality for safe disposal instructions.</p>

## Safety and Handling Considerations

As with any marine activity, take caution when deploying your Spotter. Ensure that you are familiar with the operation of your watercraft and have the necessary safety gear and safety precautions in place prior to your deployment. Secure your Spotter while it is in transit so that it is not lost or damaged. When deploying your Spotter from a boat, stay clear of all lines, especially when deploying a mooring weight.

Your Spotter contains a lithium-ion battery. Do not attempt to replace the battery yourself—you may damage the battery, which could cause overheating, fire, and injury. Do not drop Spotter onto hard surfaces or subject Spotter to extreme temperatures (below  $-20^{\circ}\text{C}$  or above  $45^{\circ}\text{C}$ ) or fire as doing so may damage Spotter or its battery. Dispose of batteries according to your local environmental laws and guidelines.

Any damage caused to your Spotter by incorrect use or unauthorized modification or disassembly may void your warranty. You are responsible for following all laws and securing all necessary permits required for your application.

## Disposal Guidelines

Spotter's electronic components and the lithium-ion battery are not generally suitable for disposal in standard municipal waste systems. Please contact your local provider to determine proper disposal and recycling options.

If in doubt, please contact us anytime at [support@sofarocean.com](mailto:support@sofarocean.com) to discuss recycling options for your Spotter.



**Sofar Ocean Technologies, Inc.**

Pier 28 Annex

San Francisco, CA 94105

USA

EMAIL [support@sofarocean.com](mailto:support@sofarocean.com)

WEB [www.sofarocean.com](http://www.sofarocean.com)